

# Lashing

## Essentials

Lashings are used to join together poles or spars to enable the construction of objects and structures. In Scouting this activity is called pioneering. Common pioneering projects include gateways, bridges and platforms, or smaller camp items such as washstands, chairs, benches and tables. See the factsheet on pioneering for more information.

## Simple lashings

### Square lashing

A square lashing is the most widely used lashing for securing one spar to another when they cross at an angle. It is particularly used to stop spars sliding over each other.

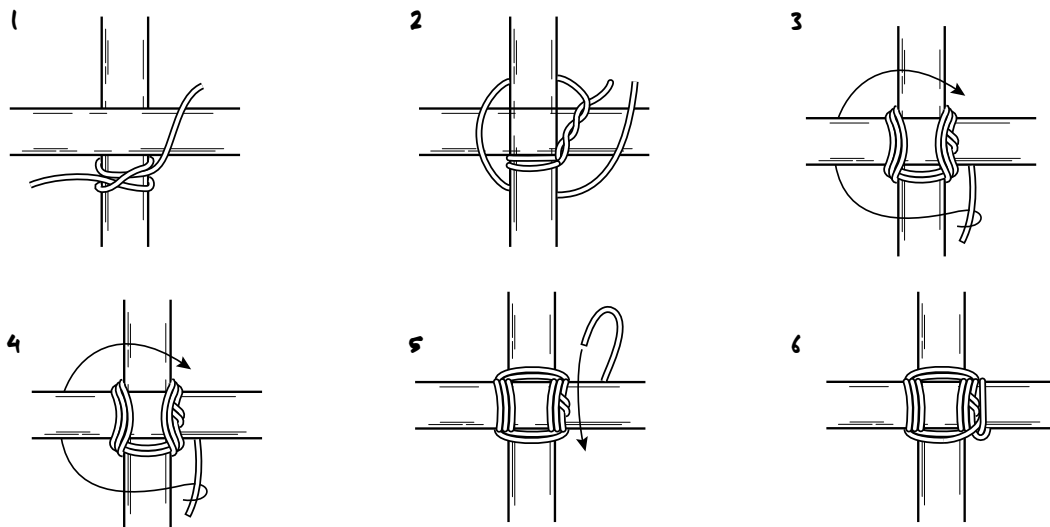

## Diagonal lashing

A diagonal lashing is used to pull two spars together and prevent them from springing apart, for example, at the cross-brace of a framework.

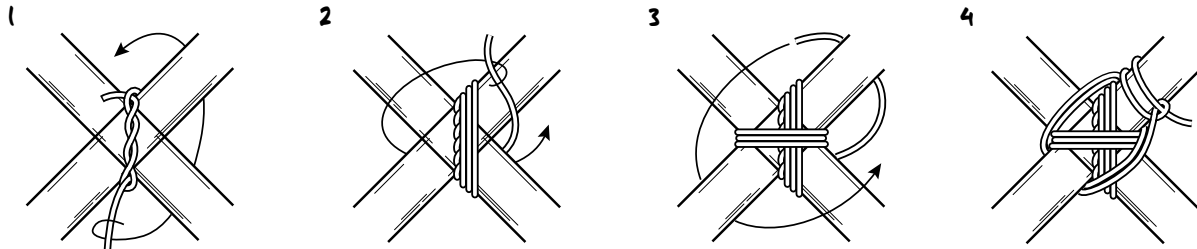

## Sheer lashing

There are two types of sheer lashing. The first is used to join together two spars to make a longer length, for example, when making a flagpole. The second type is used to create sheer legs, where the spars are lashed together at one end and opened to form an inverted V-shaped support.

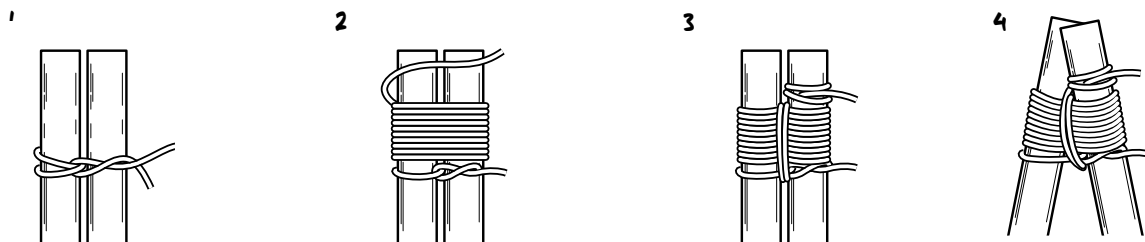

## Figure of eight lashing

The figure of eight lashing is also known as the round or tripod lashing. It is used to bring together three spars to form a tripod or gyn.

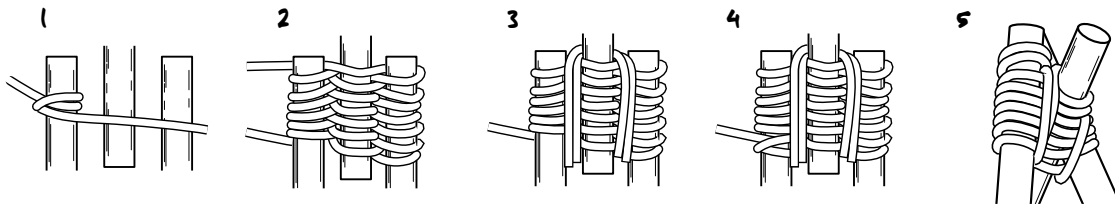

### Good practice

- Know your knots before attempting to learn lashings, particularly the clove hitch and the timber hitch, which are essential elements of a lashing. The clove hitch is used to secure a rope to a spar, as when beginning a lashing. It is far more secure than a single half hitch. The timber hitch is used to secure the end of a rope to a spar.
- The key to making secure square and diagonal lashings is to keep them tight and tidy, particularly when frapping. This is when the lashing is passed round one spar and then completely round between the spars, over and under at least three or four times, to draw the whole joint firmly together. It requires tight work, and is best done in pairs, with one Scout pulling hard on the end of the lashing while their partner ensures the turns at each corner are as tight as possible. However, ensure that lashings used to make sheer legs and tripods have sufficient play to permit the spars to open out to form a solid base.
- When finishing a lashing with a hitch, make sure it cannot slip round the spar and loosen the lashing.
- Spars and pioneering poles will last much longer if they are stripped of bark before use. Try to source spruce, larch or ash, and avoid brittle woods like willow and poplar.
- Use good quality rope such as 8 or 10mm diameter sisal for lashings that will take a strain, though thinner sisal can be used for small pioneering projects.
- If learning how to tie lashings for the first time, use cardboard tubes rather than wooden spars. Tubes are smooth and of a constant diameter, making them easy to handle.
- Blocks and hooks will be needed for more advanced pioneering projects such as aerial runways, hoists and swings.

## SAFETY GUIDELINES

- Ensure that Scouts can tie lashings confidently and securely before undertaking pioneering projects.
- Run small scale pioneering projects before progressing to large scale outdoor projects.
- Always carry out a risk assessment before undertaking any pioneering activities.
- Ensure that pioneering structures are safe and properly anchored before allowing anyone to use them.

### Find out more

The Outdoor Adventure Manual (Haynes, 2013) and The Complete Guide to Scouting Skills (Doubleday, 2010) are useful introductions to lashings. Many other publications on pioneering and lashings are available, which introduce other types of lashings and offer extra project ideas. Former Gilwell Park Camp Chief John Thurman wrote a number of classic pioneering guides including Pioneering Projects, Fun with Ropes and Spars, and Progressive Pioneering.

Discovery Channel, sponsors of the Scout Pioneer Activity Badge, has produced an activity pack for Scouts with accompanying notes for leaders. Find out more at [scouts.org.uk/discovery](https://scouts.org.uk/discovery)